

**RACKS MATRIX**  
storage advanced solution



[www.edmagsa.com](http://www.edmagsa.com)

مصنع إدماج الفضاء للصناعة



بِسْمِ اللَّهِ الرَّحْمَنِ الرَّحِيمِ



رؤية VISION

2030

المملكة العربية السعودية  
KINGDOM OF SAUDI ARABIA



**Racking Systems:**

Our Clients.....3

Warehouse Safe.....4

Selective racking system.....5

Drive -IN racking system.....8

Drive -Thru racking system.....9

Mezzanine Racking system .....10

Radio shuttle racking system.....12

Cantilever racking system.....14

Flow racks system.....15

Stack racks system.....16

Light duty racking system.....17

Automated storage and retrieval systems ASRS or AS/RS.....18

**Super Market Equipments:**

Refrigeration equipments .....20

Super market shelving system.....23

Checkout counters.....26

Logistics .....27

Bakery Solutions.....28

Island Shelving.....29

## Our Clients



# WAREHOUSE SAFETY

## SWL Signs

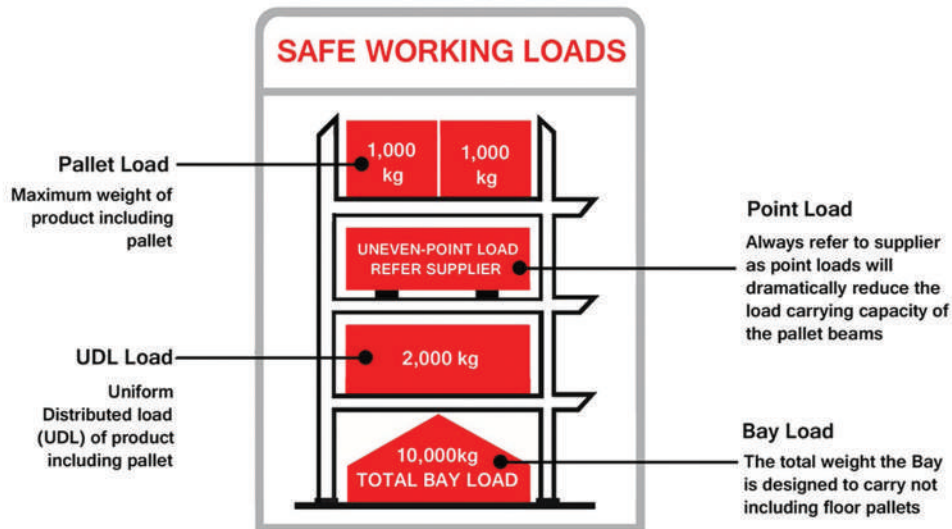

### ENTERING THE RACK

- To safely deposit or retrieve a pallet the forklift **MUST** approach the racking squarely and not at an angle
- **DO NOT** attempt to deposit or retrieve a pallet when the forklift is not aligned correctly
- **DO NOT** nudge a pallet to position it correctly in the rack

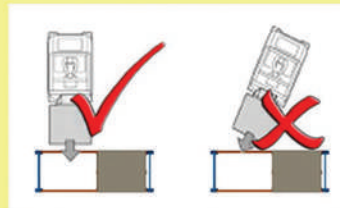

### LOAD PLACEMENT

Incorrect placement of loads can be dangerous

Loads should be evenly distributed across the beam length

Pallets should be positioned correctly

Pallet weight should not exceed design load

Loads should be positioned evenly across the pallet



## Selective Racking System

Selective Pallet rack is a material handling storage help system designed to store materials on pallets.

It is conventional industrial shelving, and pallet racking or APR (Adjustable Pallet Racking). The most universal system for direct access to every single pallet.

This is a manual storage system that are operated by handling equipment controlled by operators

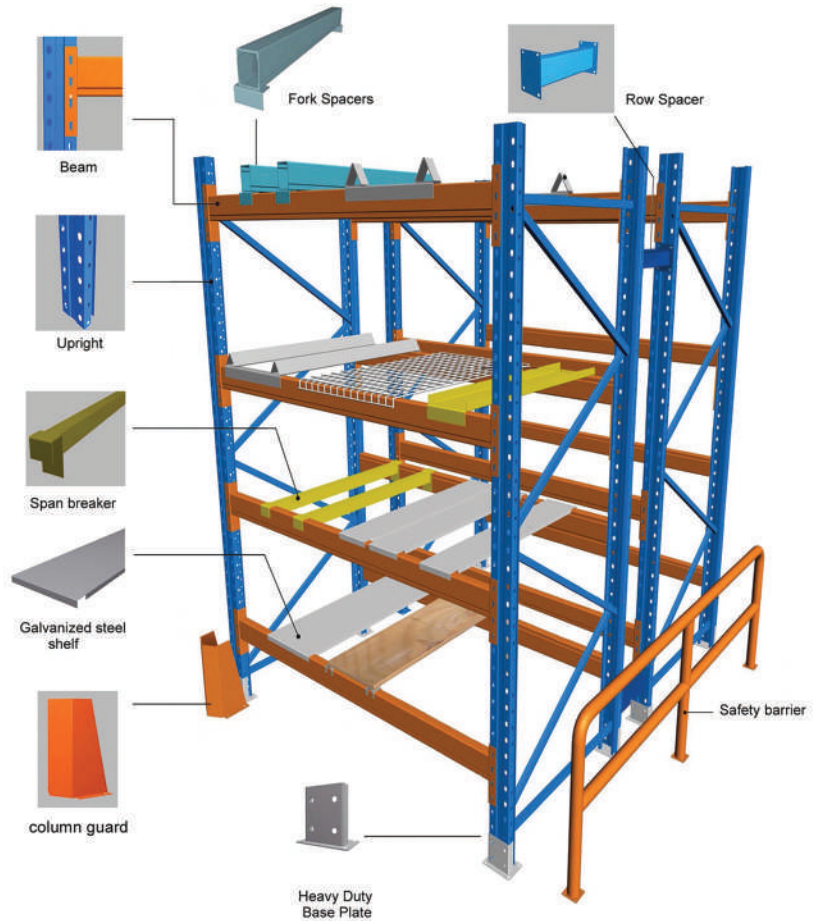

### Beam Dimensions

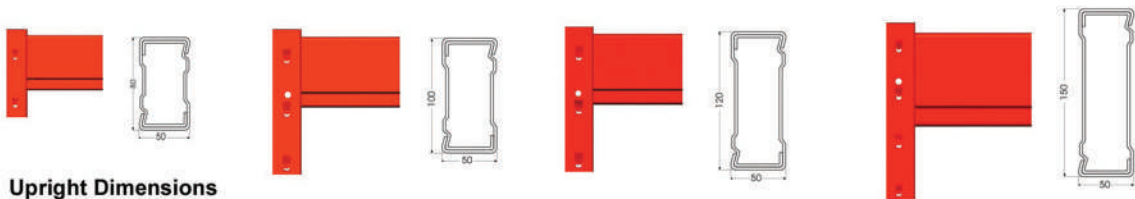

### Upright Dimensions

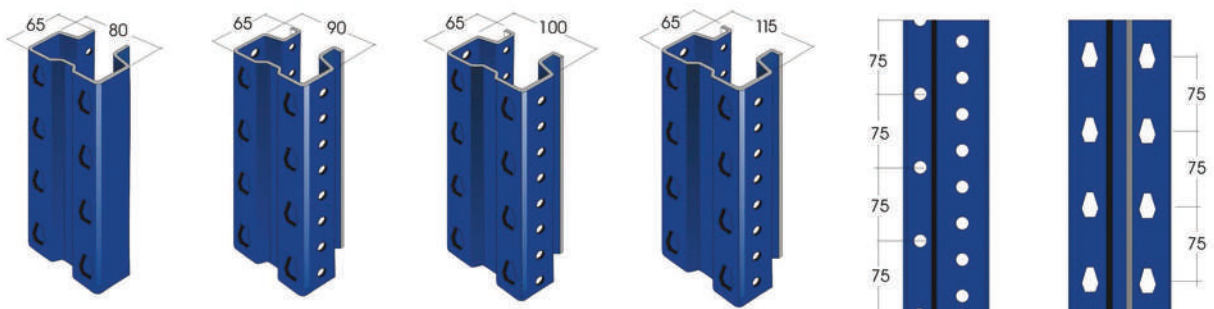



## Selective Racking System





## Selective Racking System

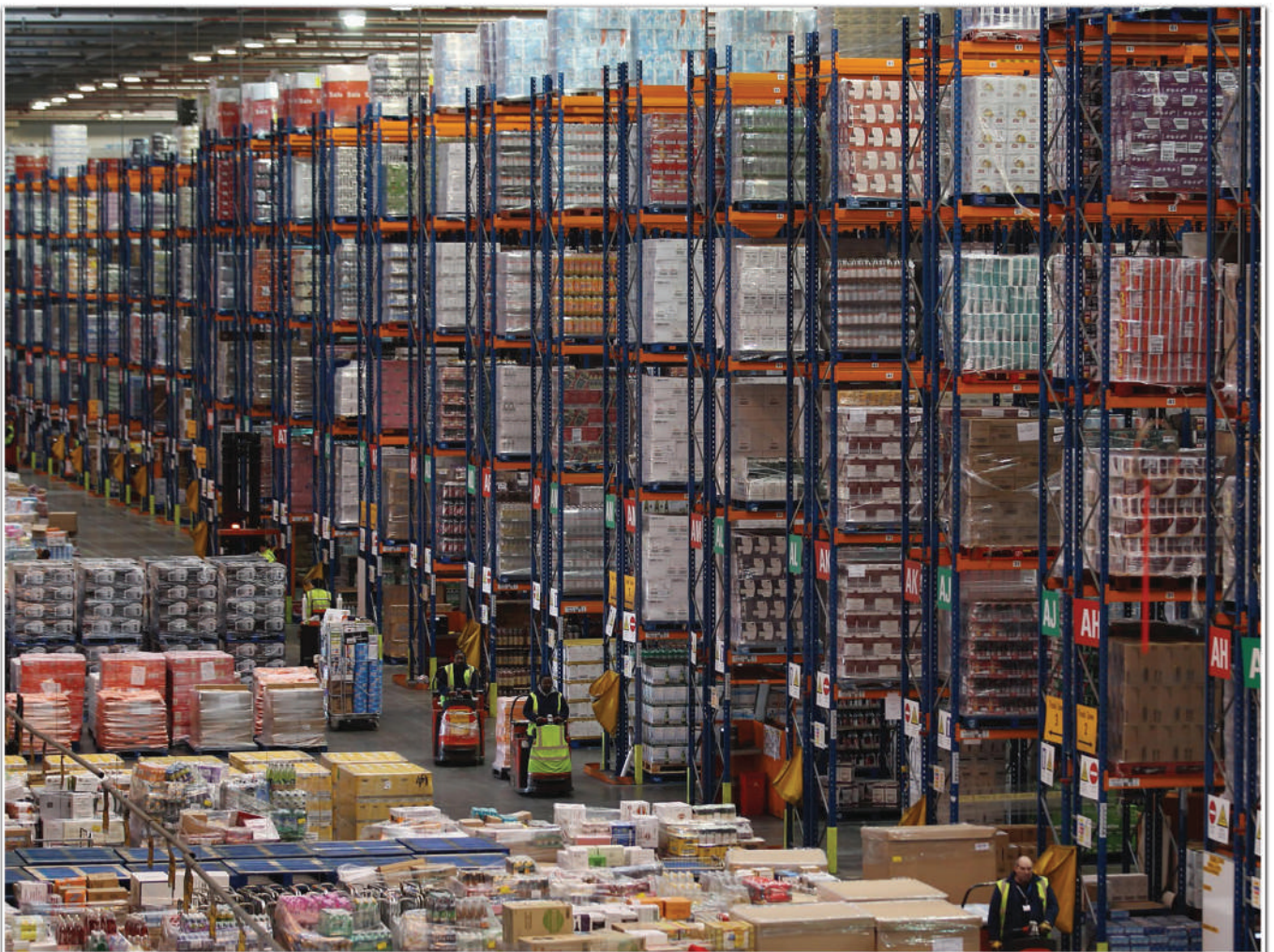
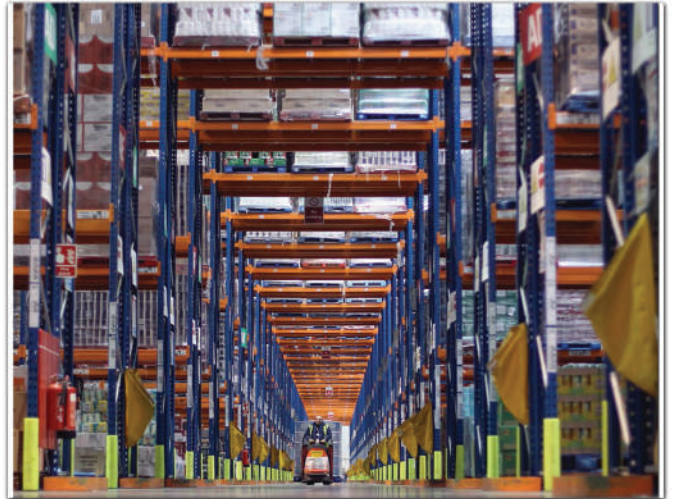



## Drive-In Racking System

The Drive in Racking System is a high-density storage solution that maximizes available space and height in the warehouse by reducing the forklift operating aisles. It is made up of an easy-to-assemble and -reset modular structure, which makes it easy to maintain. Compact racking can be either Drive in racking, with only one access aisle, where the last load in is the first one out

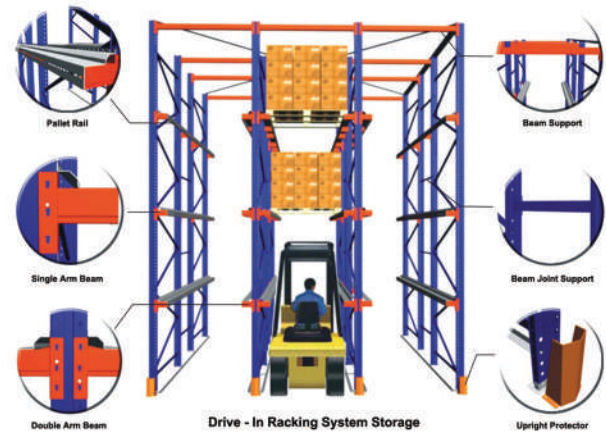



## Drive- Thru Racking System

### Drive - Thru

This solution requires two accesses, one on each side of the racking, the first load in is the first one out.

Because it allows access from both sides the front and rear, drive through racking system is a suitable system for high turnover products.



### Drive - In

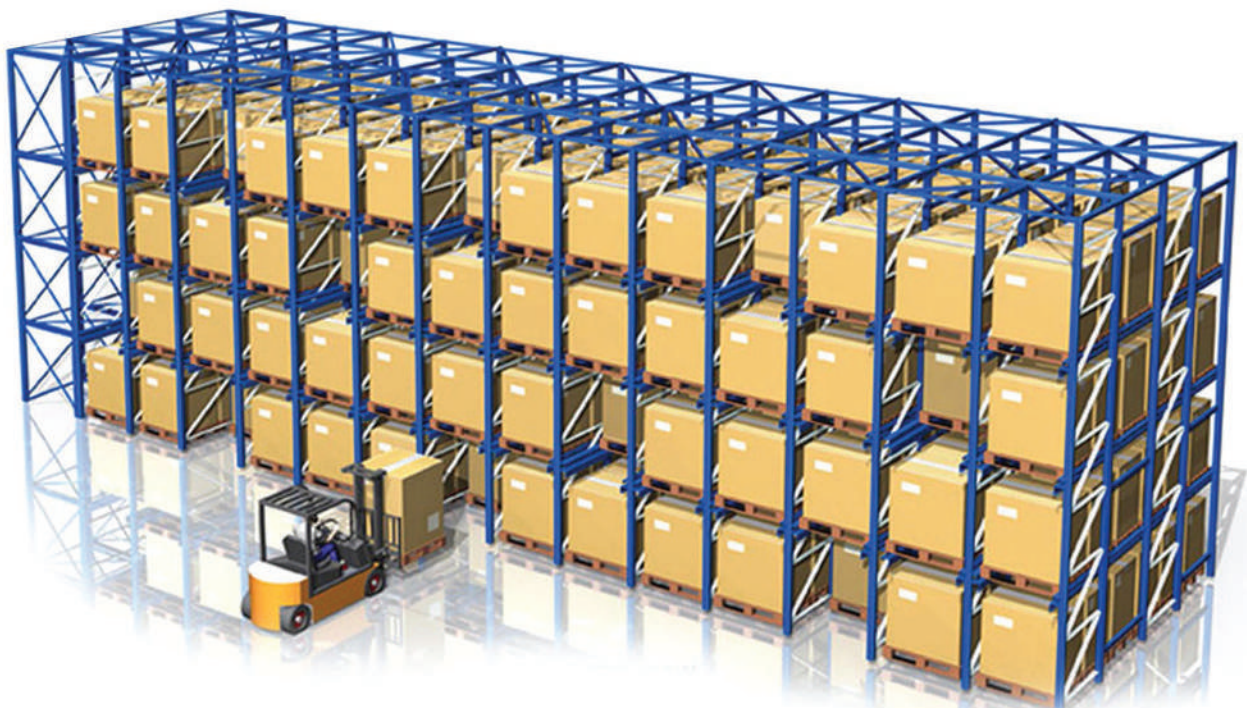



## Mezzanine Racking system



Mezzanine is a multi-store rack system that provides efficient use of the storage capacity.

Storage space can be saved much better by means of the rack's height.

The system allows convenient access to any section.

Products on all levels are stored on pallets or on shelves directly.



## Mezzanine Racking system





## Radio Shuttle rack

This high-density pallet storage system simplifies loading and unloading goods by utilizing an electric cart.

A forklift sets the pallet on top of the Radio Shuttle. The cart then moves along the track to place the load in the correct location. Using a remote control, the operator can execute all procedures for storing and extracting pallets.

High precision sensors control how the Radio Shuttle moves the stored load.

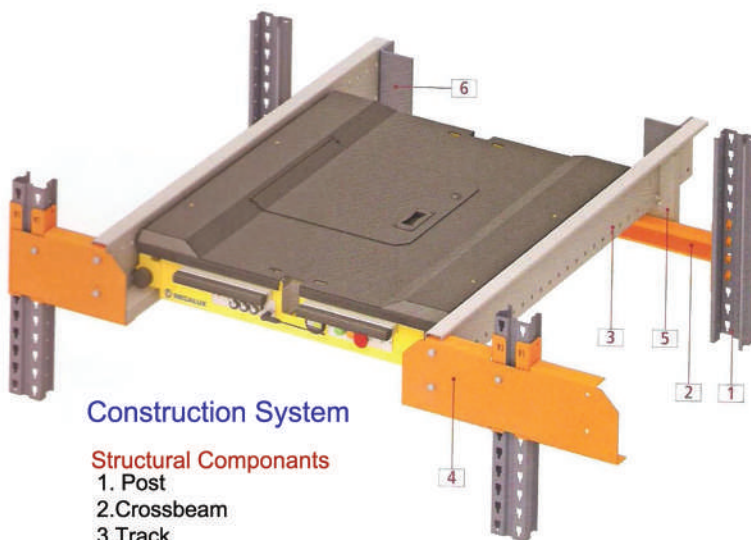

### Construction System

#### Structural Components

1. Post
2. Crossbeam
3. Track
4. Exterior track
5. Interior track support
6. Track bumper

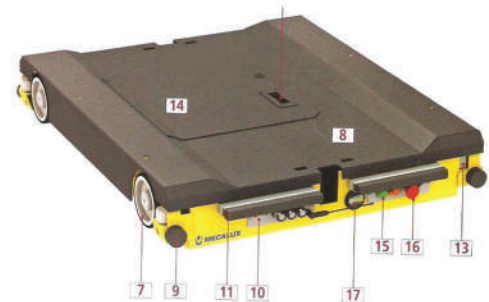

#### Shuttle Components

7. Wheels
8. lifting platform.
9. Bumper
10. Operating mode indicator
11. Anti-catch safety bumper
12. Battery access tabs
13. Position sensors
14. Rapid rechargeable battery
15. Movement direction light
16. Emergency button
17. Battery status warning sign

## Radio Shuttle rack

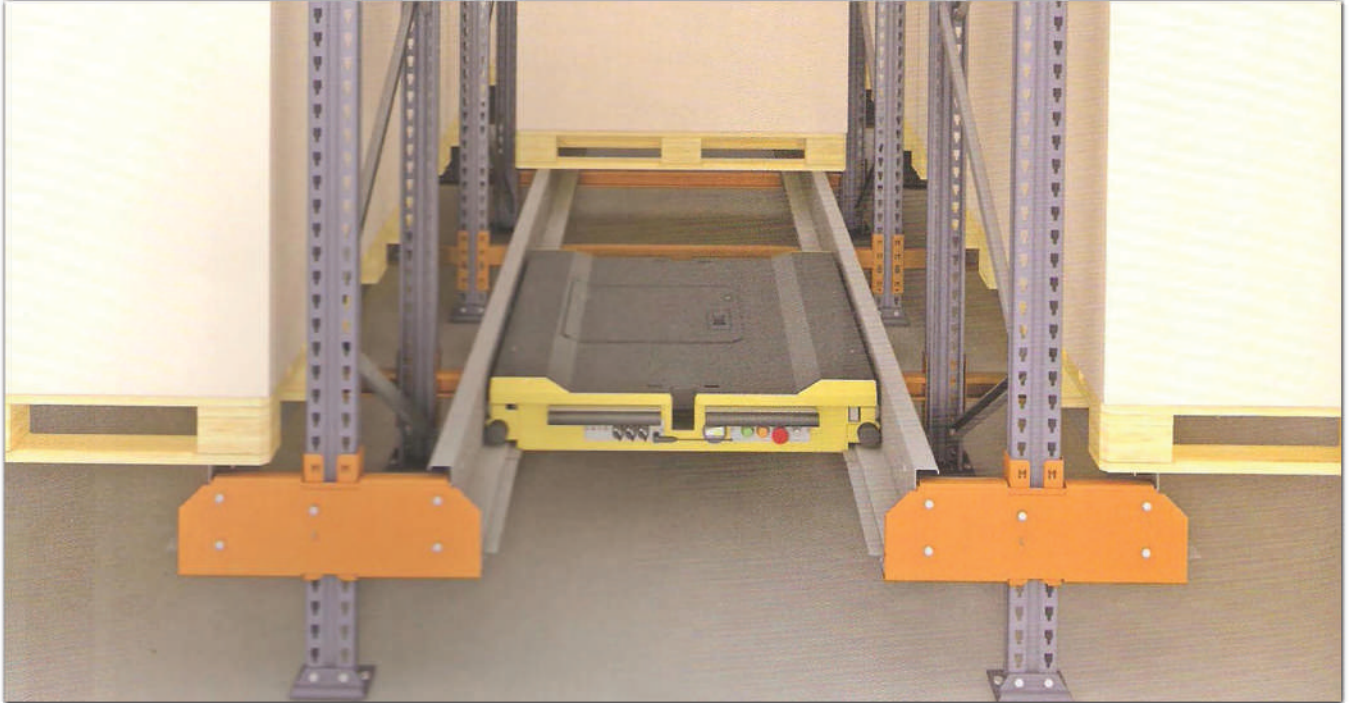

### General features

This is a semiautomatic compact pallet storage system that uses shuttles to move independently within the rack itself; forklifts do not need to reach inside the storage lanes. The forklift sets the load on top, the Radio Shuttle which then moves along the track to deposit the load in the right location, several high precision sensors control how the stored load moves. The forklift operator performs all the procedures for storing and extracting pallets simply by using a remote control

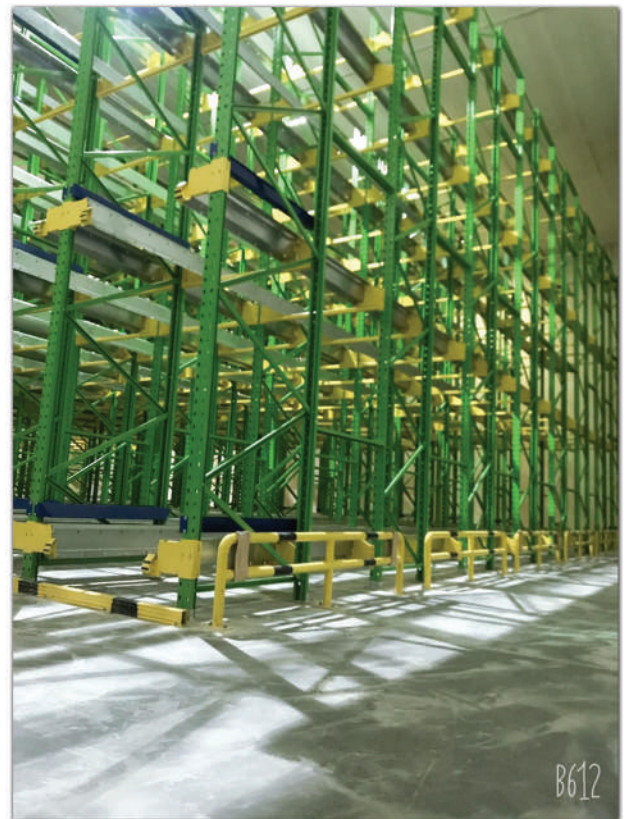



## Cantilever System

The Cantilever Racking is ideal solution for storing long and bulk volume loads in: such as tubes, beams, etc.  
This type of specific solution is made up of a base, columns, and strong and versatile cantilever arms.



## Flow rack System

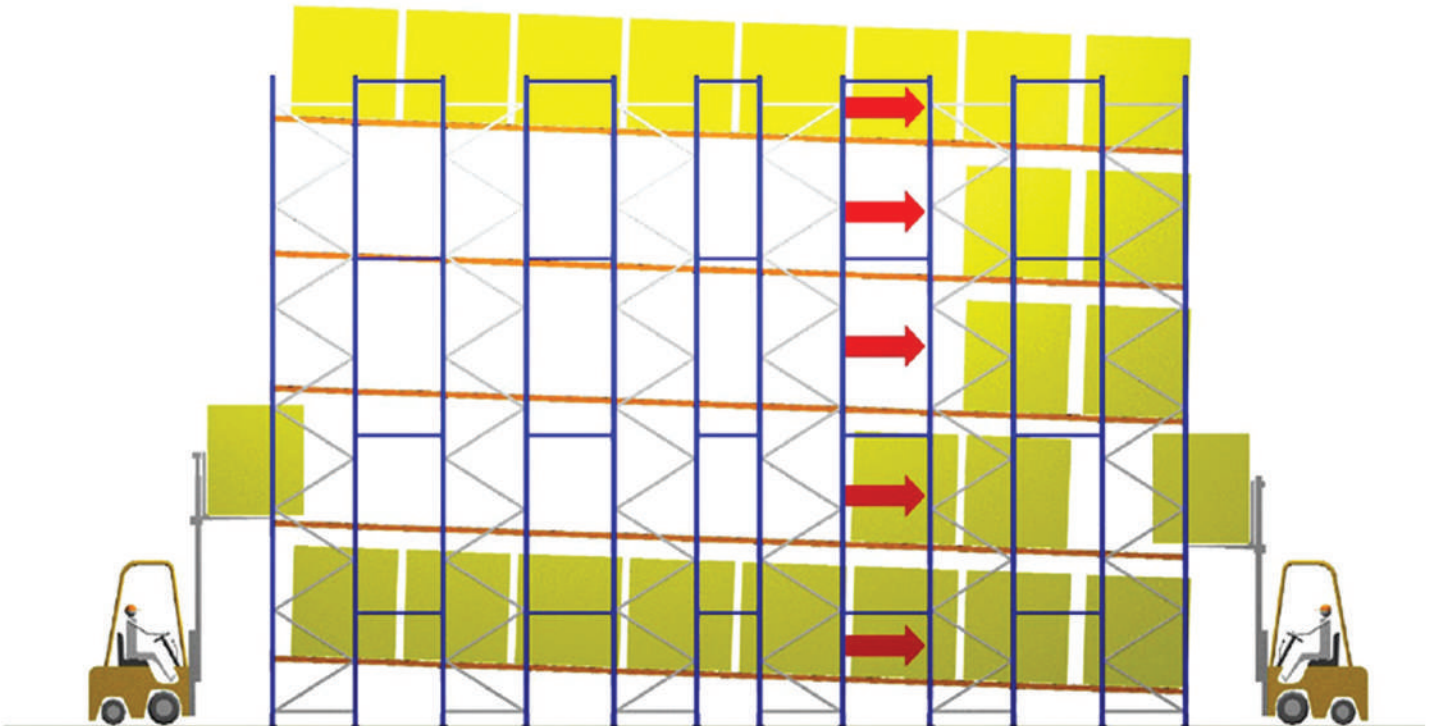

Flow rack is also called pallet flow racking, whose rollers are fixed up in the beam of the shelf at a fixed gradient and then place the pallet in the higher side, so it will be fallen depending on its own gravitation. In order to control the pallet in a steady speed and avoid the collision, a set of damping system will be set up on the roller line at every certain distance since the faster speed pallet slide, the more the resistance that damped system caused. End portion separator system set up at the low end, to separate the two lowest pallets, so that the lowest end of the pallet can be successfully picked up.





## Stack racks system



This system is durable, portable, collapsible, shippable, low-cost, stacking racks that reduces costly product damage associated with bulk stacking, offers better space utilization, product identification and easier handling of product.





## Light duty system



Light Duty Racks are ideal for small & lighter products. It's cost effective, stable, boltless (bolt & nut free), durable, save time, save space, shelves adjustable and easy install & dismantle.



## Automated storage- retrieval system (AS/RS)



Automated storage and retrieval systems, sometimes known as ASRS or AS/RS, are made of a variation of computer-controlled systems that automatically place and retrieve loads from set storage locations in the store with precision and speed.

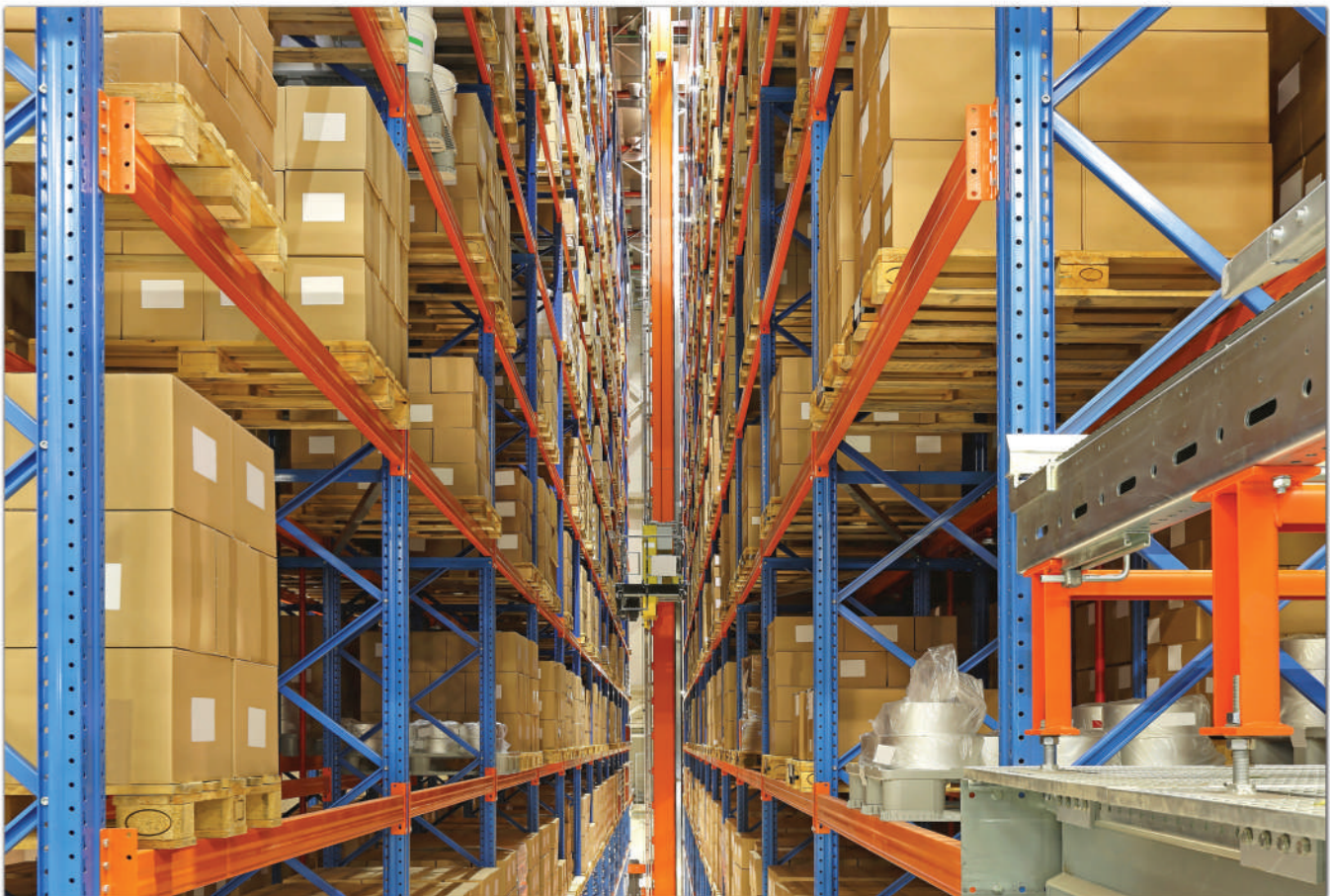



## Super Market Equipments

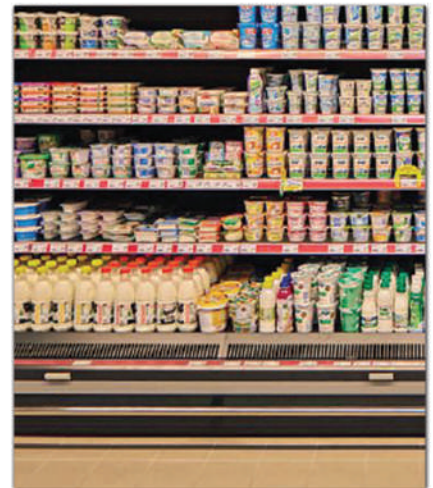



## Refrigeration Equipment

### Multidecks CoolJet S

Refrigeration equipment is a key element of any commercial facility.

Different retail formats: convenience stores or supermarkets, or bakers rely on refrigeration as it ensures all products are properly displayed keeping their nutritional values.

Our Refrigeration equipment is represented by wide range multidecks models, counters and beverage coolers.

A variety of sizes, temperature conditions and refrigerating systems are available to meet all individual requirements.



### CoolJet S with sliding doors



#### Key features

- Doors increase energy efficiency
- Energy-efficient fans are optional

### CoolJet S with hinged doors



#### Key features

- Glass doors reduce multideck's energy consumption
- Options: energy-efficient fans, hinged low-temperature doors for -2 / -4 °C (temperature inside cabinet)

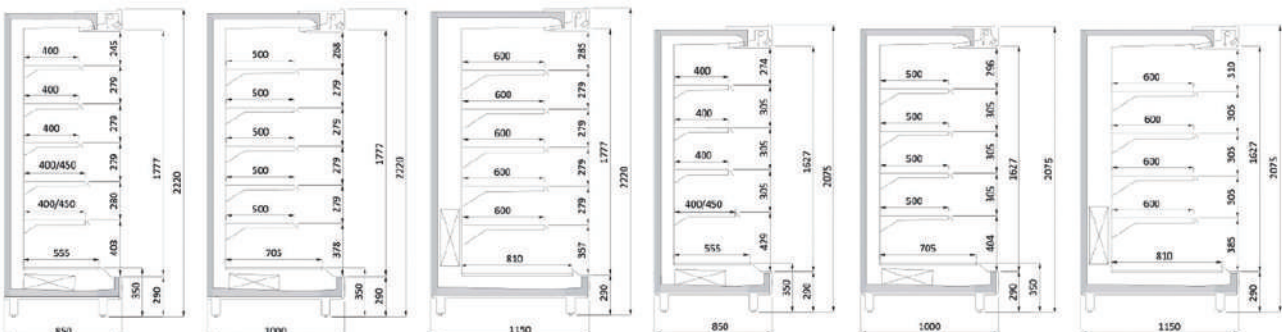

# Refrigeration Equipment

**CoolJet GL**

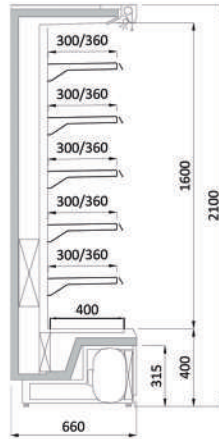

**CoolJet GL with sliding doors**



**Key features**

- Can be installed in a line or as a stand-alone unit
- Large product-facing area
- LED light
- No TEH defrosting



**Key features**

- Energy-saving sliding doors
- LED light
- Eco-friendly refrigerant R290 (Propane)

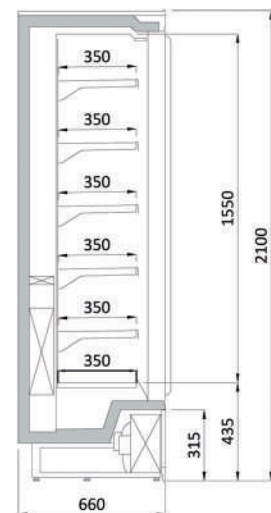



## Super Market shelving system

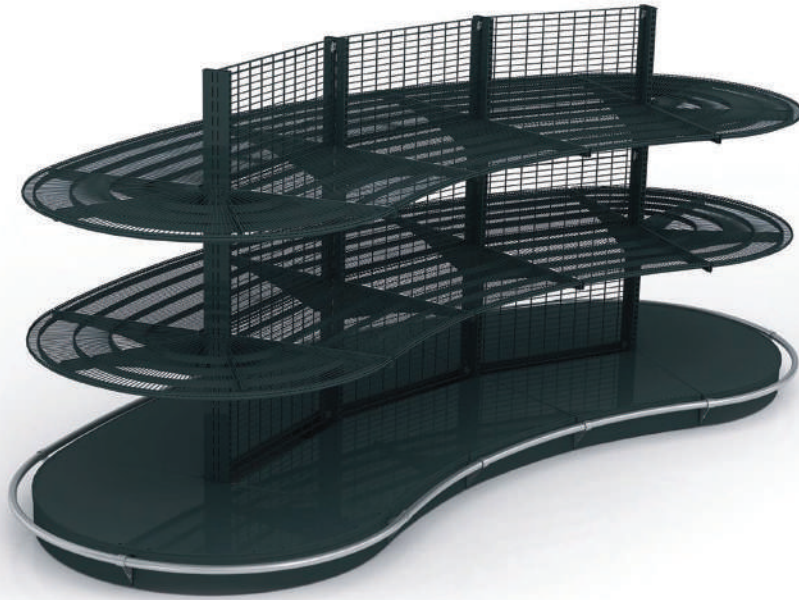

### Wire Solutions

Wire shelving brings the products in the centre of attention. Due to its flat design, the shelving provides the maximum of merchandise density, looks stylish and

### Key Features

- Modern design
- Perfect solution for different retail formats
- Less metal used in shelving design

### Customized Solutions

Straight and curved display units meet all merchandising requirements and stand out from the standard shelving systems. Different design options help to reach the necessary customization within the store and make the customer totally absorbed by the perfect shopping experience



# Super Market shelving system

## Shelving System FS

FS system stands out from the standard shelving as it suggests additional aisles space. Middle back panel together with new shelf size gives extra space which means more comfort for customers and efficient merchandising.

### Key Features

- Central back panel
- Modular design
- Different size options
- Wide range of accessories
- LED backlight



## Less is More

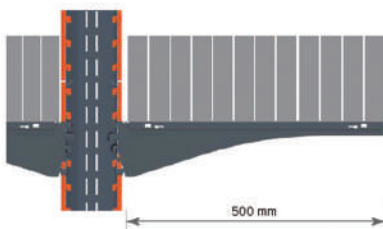

**KM system**

Two back-panels — 10 cm lost space

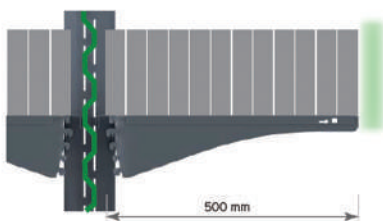

**FS Shelving system**

**Middle Back Panel** substitutes two back-panels.  
Gives extra 10 cm space in the row



**Middle Back Panel**  
5 cm reduced depth  
Gives extra 20 cm space in the row

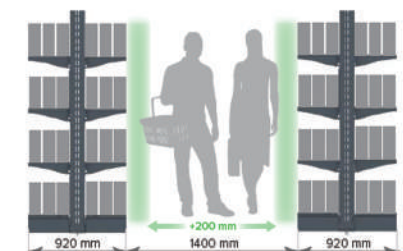
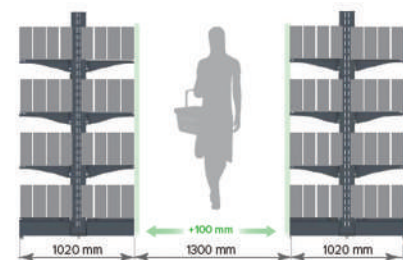
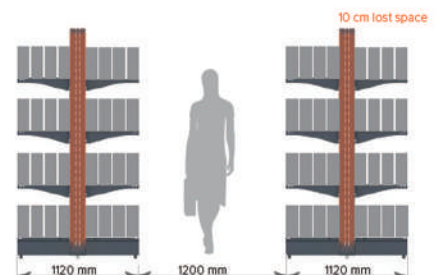



# Super Market shelving system

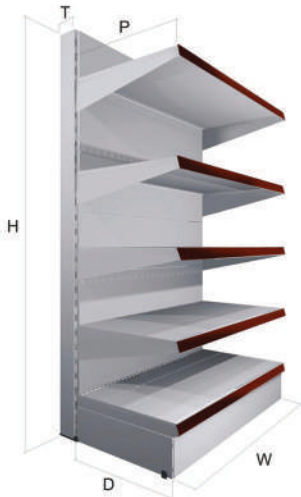

STANDARD DIMENSIONS FOR WALL GONDOLA SHELVINGS

H Height (mm)	W WIDTH (mm)	D Base Depth (mm)	T Thickness (mm)	P Shelf Depth (mm)
1700	500	300	80	300
1950	750	400	100	400
2200	1000	500	140	500
2450	1250	600	-----	600
3200	-----	-----	-----	-----

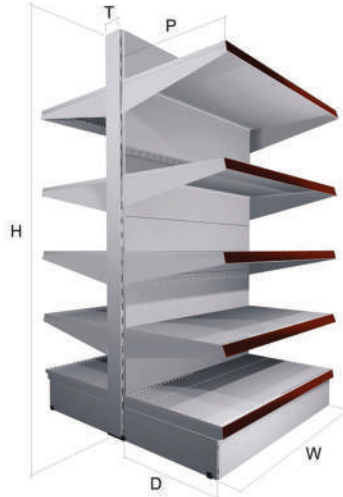

STANDARD DIMENSIONS FOR ISLAND GONDOLA SHELVINGS

H Height (mm)	W WIDTH (mm)	D Base Depth (mm)	T Thickness (mm)	P Shelf Depth (mm)
950	500	300	80	300
1200	750	400	100	400
1450	1000	500	140	500
1700	1250	600	-----	600
1950	-----	-----	-----	-----
2200	-----	-----	-----	-----
2450	-----	-----	-----	-----

## STANDARD DIMENSIONS OF THE SHELVINGS

The diagrams shown below refer to the standard dimensions of the suspended shelves and base shelves.

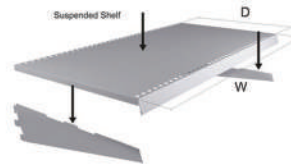

W WIDTH (mm)	D Depth (mm)	Number of reinforce- ment
1000	300	1R
1000	400	2R
1000	500	2R
1000	600	3R
1250	300	1R
1250	400	2R
1250	500	2R
1250	600	3R

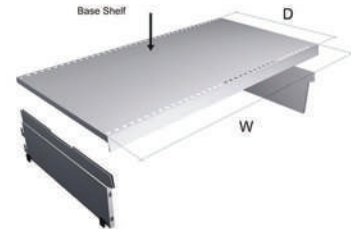

W WIDTH (mm)	D Depth (mm)	Number of reinforce- ment
1000	300	2R
1000	400	2R
1000	500	3R
1000	600	3R

W WIDTH (mm)	D Depth (mm)	Number of reinforce- ment
1250	300	2R
1250	400	2R
1250	500	3R
1250	600	3R



ISLAND GONDOLA



CORNER WALL GONDOLA

## Checkout Counters



### DIAMOND Checkout

Designed with the stainless steel bumper, the checkout gets the most of reliability and style.

- Long-term operating
- Premium segment
- Highest quality
- Wide range of accessories
- Working place and service ergonomics
- IT-equipment integration

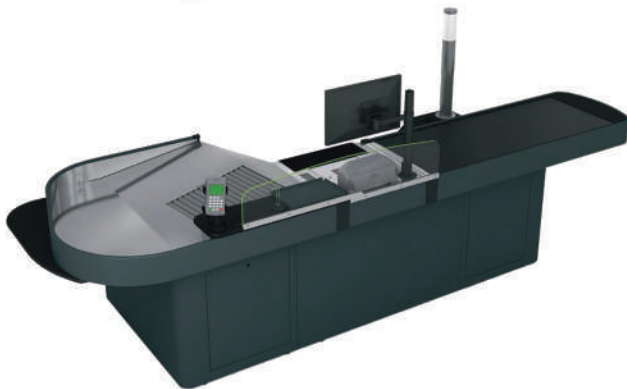

### FLEXI Checkout

The perfect choice for any retail format.

- Shapes diversity
- Any part of a checkout can be modified and customized
- Modular system
- Optimal «price-quality» ratio
- Safety service



### CLASSIC Checkout

Reliability proved by years of experience.

- Long-term operating
- Best materials used
- Wide choice of bumper colours (RAL)
- Wide range of accessories
- Easy to install

### Self-Checkout

#### Key Features

- Ergonomics and reliability
- Capacitive touchscreen
- Cash management system (option)
- Test scales up to 200 kg (option)
- Frame color selection
- Easy installation and maintenance





## Trolleys and Logistics

### Multifunctional Roll-containers

Performs the functions of storing and moving products in retail outlets and logistics centres. It is light and portable, suitable for various kinds of products.

Folded roll container occupies minimum space. The design allows to insert the containers one into another.



### Pallet containers

Designed for the storage of products on pallets in the retail outlets and warehouses.

Containers with pallets can be stacked on the top of each other, wherein the second level is able to support the load of 800 kg.

They are convenient for transportation and allow saving storage space without special racks.



### Customized solutions

This is a customized solutions such as functional containers with shelves for distribution logistics. The cell size can be adapted in accordance with the client's needs for the safe transportation of any product. Depending on the design, containers can support a load of up to 1000 kg.

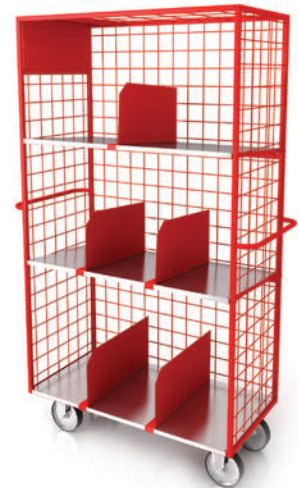

### Super Market Trolley



## Solutions for Bakery

Bakery department is one of the most attractive areas in any store format.

Properly merchandised, it makes a fabulous first impression on any customer and stimulates purchases. We suggest special shelving for bakery that stands out with appealing design, ergonomics and functionality Solutions for Bakery



### Key Features

- Modern design
- Perfect solution for different size of products
- Water-based lacquer coating of wood surfaces
- Customizable solutions
- Perfect product observation
- Durability



Movable section dividers

Baguette solutions

Shelves with lift doors



Excellent product layout

safety barrier

Solution for packages



Warm white LED backlight

Acrylic barriers

Sliding drawer doors



# Island Shelving

Island shelving and two levels for products layout provide an easy access from different sides. Perfect design attracts customers' attention on goods and motivates to purchases. Modular sections allow different product presentation.

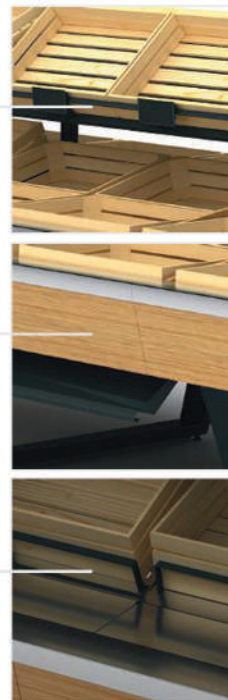
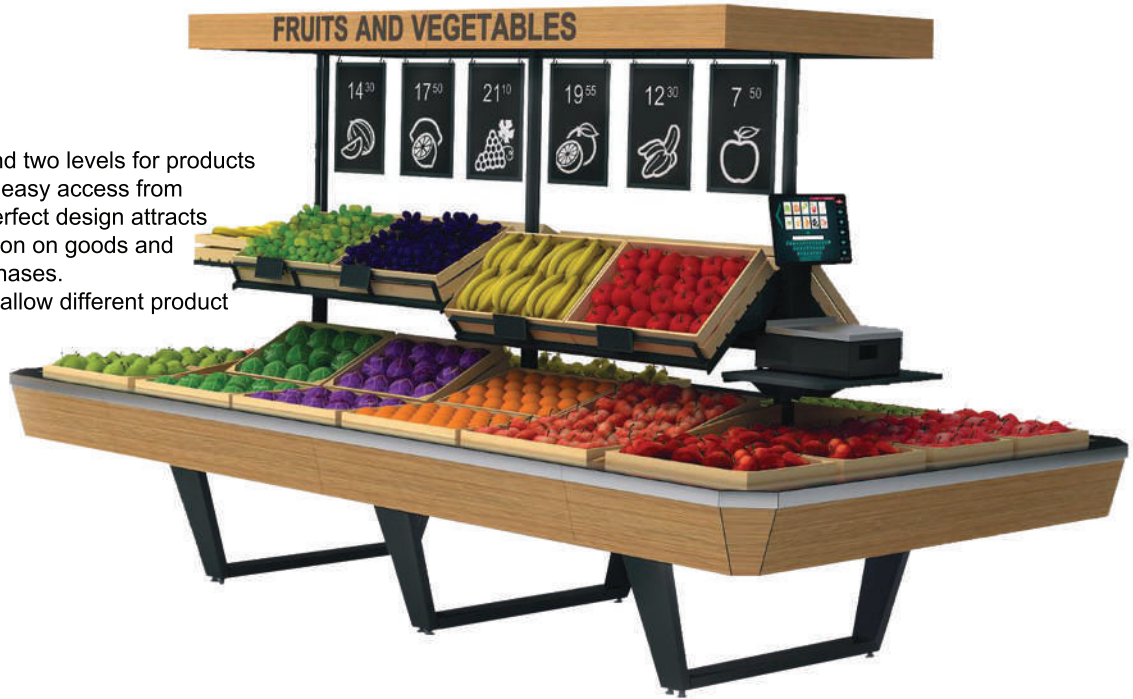

Shelves inclination can be modified - allows better product observation

Shelves for waste collection

Barrier-dividers of the bottom shelf. Stainless steel surfaces: hygiene, durability and corrosion resistance



Our Design and Engineering Department as a compliment of more than 10 expert Designers and Engineers. The latest Technology regarding structures and loading of racking. We provide effective and reliable storage system to all kinds of customers.

In order to provide good customers service. Our project team follow standardized operational procedures.

Well-trained sales engineers visit all prospective customers and discuss their needs.

Our experienced designers design a tailor-made system for each project.

Our customer service teams provides our customers with up-to-date information in respect of manufacturing progress delivery schedule and installation services.

Our installation engineers supervised all installation work.







## **RACKS MATRIX**

storage advanced solution

Al-Mishal Dist. Riyadh 14327 - 6518  
Kingdom of Saudi Arabia  
Mobile : +966 557 667 476  
E - mail : [info@edmagsa.com](mailto:info@edmagsa.com)

[www.edmagsa.com](http://www.edmagsa.com)